



ALA-5

ACOUSTIC LINEAR ARRAY LOUDSPEAKER SYSTEM

DESCRIPTION:

The ALA-5 is the most versatile member of Apogee's Linear Array loudspeaker family. Its tremendous power output and precise directivity enable it to handle the most demanding professional requirements. The ALA-5 is modest in size and easy to handle.

DRIVER COMPLEMENT:

LOW FREQUENCY: Dual Apogee 15" (381 mm) permanent magnet cone-type drivers, Ferrofluid® cooled 4" (102mm) Voice Coils; cone treated with a waterproofing compound, providing resistance to moisture, and enabling long-term stability of cone resonance and cone mass parameters

HIGH FREQUENCY: Dual Apogee 1" (25 mm) throat composite compression drivers treated with Ferrofluid® for greater power handling capability, lower distortion, and control of short-term impedance rise

INPUT CONNECTORS:

Neutrik™ NL4MP Speakon™ connectors standard; Cannon AP series and gas-tight barrier strips optional

COMPATIBLE PROCESSORS:

DLC24 Digital Controller

RIGGING HARDWARE:

Internal formed steel channels accept fully encapsulated steel joining bars, secured by aircraft-grade quick-release pins; all rigging parts are recessed

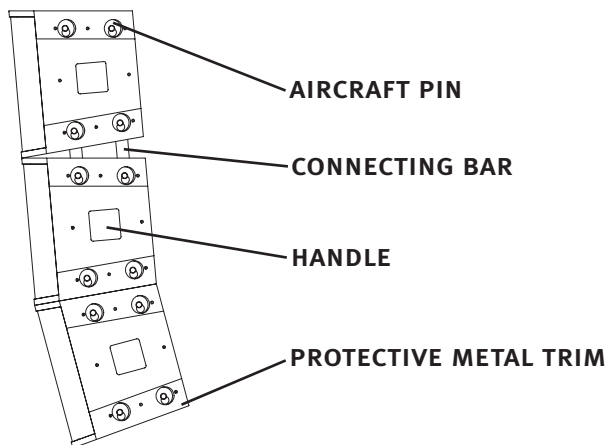

Apogee's unique rigging system makes assembly quick and easy. Enclosures are joined together by choosing the proper length connecting bars to achieve either a flat-pack formation or a tight-pack formation. The bars are secured in place with aircraft grade retention pins.

ENGINEERING DATA:

FORMAT:

Bi-amped/Two-way/Electronically-coupled

DISPERSION:

ALA-5 H: 45° x V: 10°

ALA-5W H: 90° x V: 10°

FREQUENCY RESPONSE (1 M ON AXIS):

50 Hz to 17.5 kHz + 3 dB

MAX. SPL (@1M):

132 dB cont./138 dB peak

PTML (PEAK TRANSIENT MECHANICAL LIMIT):

149 dB

SENSITIVITY (1 W @ 1 M):

LF: 99 dB SPL

HF: 110 dB SPL

NOMINAL IMPEDANCE:

LF: 4 ohms HF: 4 ohms

MAX. POWER HANDLING:

LF: 900W cont./ 3600W peak

HF: 300W cont./ 1200W peak

DIMENSIONS:

front: 43.3" (1100mm) W x 18.4" (468mm) H

rear: 36.5" (928mm) W x 15.7" (399 mm) H

depth: 15.4" (392mm)

WEIGHT:

141 lb. (64 kg) without rigging bars

APOGEE
SOUND INTERNATIONAL

FIVE ALA-5 SPEAKERS

The graph displayed below depicts the vertical beam width of an array of five ALA-5's compared to the vertical beam width of a theoretically perfect horn. The vertical dimension of the perfect horn, at 84 inches*, is equal to the vertical dimension of the five ALA-5's.

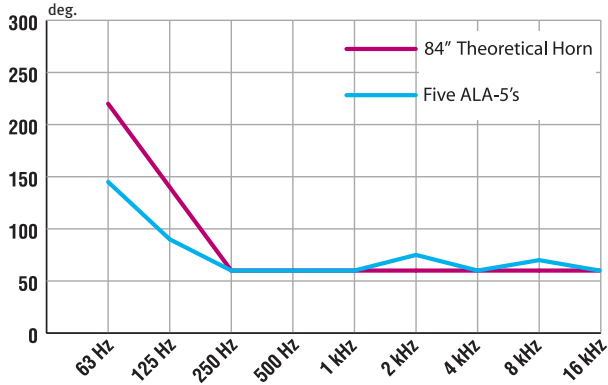

SEVEN ALA-5 SPEAKERS

The graph displayed below depicts the vertical beam width of an array of seven ALA-5's compared to the vertical beam width of a theoretically perfect horn. The vertical dimension of the perfect horn, at 115 inches*, is equal to the vertical dimension of the seven ALA-5's.

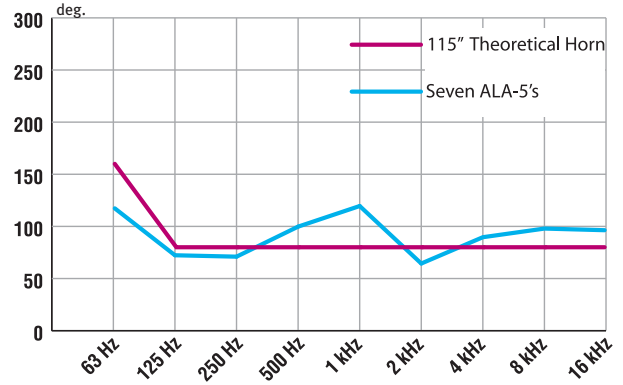

In both graphs, it can readily be seen that the Linear Array exhibits far better control than that of the horn, particularly in the lower frequencies. As more enclosures are added, the pattern control extends to lower and lower frequencies, while the directivity continues to increase.

* Note: If such a horn were to be built, its excessive depth would render it impractical to transport.

DIMENSIONAL DRAWINGS ALA-5 (dimensions in inches and millimeters)

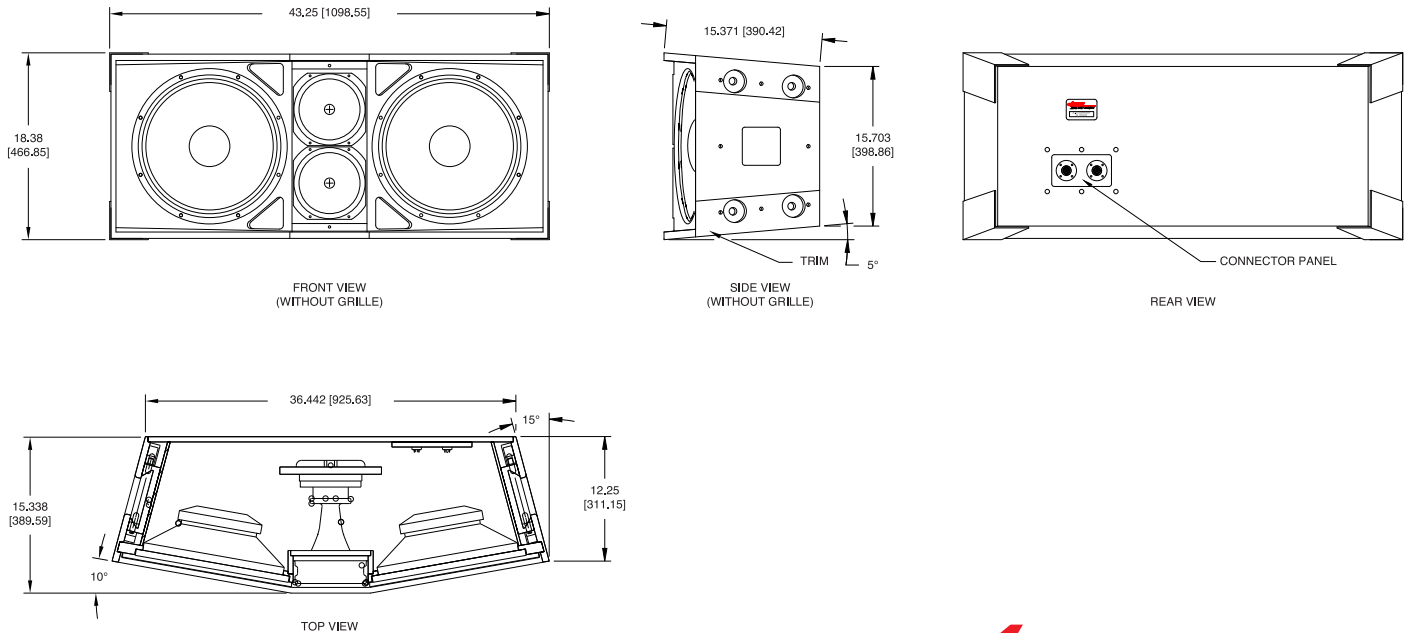

50 SPRING STREET, RAMSEY, NJ 07446, USA
 TEL: 800-443-3979 • FAX: 800-999-9016 • www.apogee-sound.com